

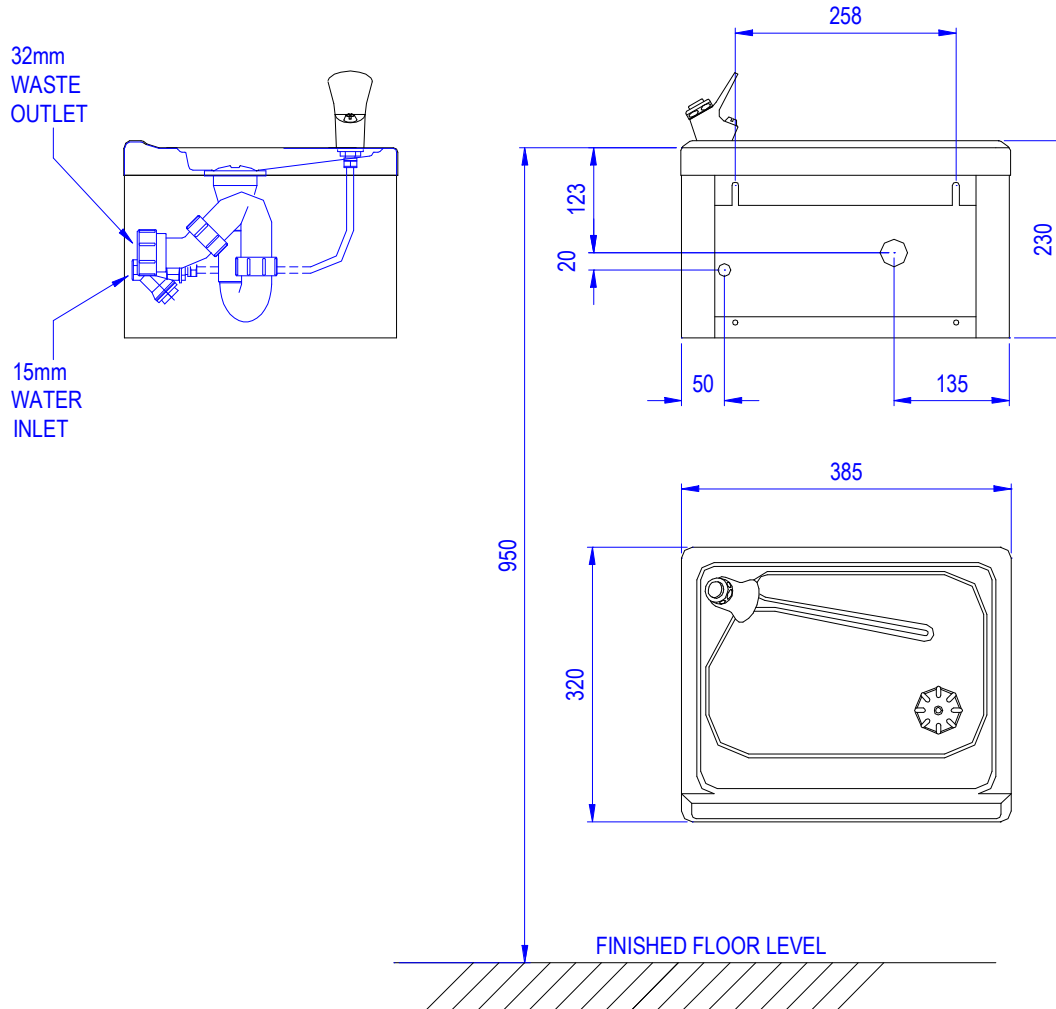

11-17 POWERSCROFT ROAD
SIDCUP, KENT. DA14 5NH
Tel: GB: +44 (0) 208 302 4035
Fax: GB: +44 (0) 208 302 8933

Technical Data Sheet



DRINKING FOUNTAIN MODEL W144

A stainless steel drinking fountain with a heavy chrome plated push button type self-regulating bubbler. With the option of fitting a glass filler instead of a bubbler, it is easily installed and ideal for public buildings, hospitals, offices, nursing homes, schools and sporting centres.

CONSTRUCTION:

Casing in brushed finished stainless steel with integral mounting points for easy installation. Access plate with tamper proof bolts.

SERVICES:

Water inlet: 15mm (1/2" BSP) brass inline strainer.

Waste: 32mm multi-fit trap.

PACKAGING:

Dimensions: 452 x 370 x 374 mm

Weight: 8 kgs.

CAUTION

Drinking Fountains On Outside Locations

During winter when temperatures may reach freezing point, it is advisable to drain the water system to prevent damage to the bubbler cartridge.

Ideally, a drain-cock should be fitted downstream of the shut-off cock and before the fountain.

To drain the system:-

1. Close off the shut-off cock and drain off at the drain-cock holding the push button in the open position until all the water has drained away.
2. Close off the drain-cock.

If a drain-cock is not available, the water can be drained in the same manner at the removable plug on the line strainer located inside the fountain.

Please note that frequent use of this item for draining purposes can lead to leakages and it should be considered as a temporary measure until such time that a drain-cock can be fitted.



Water Flow Adjustment

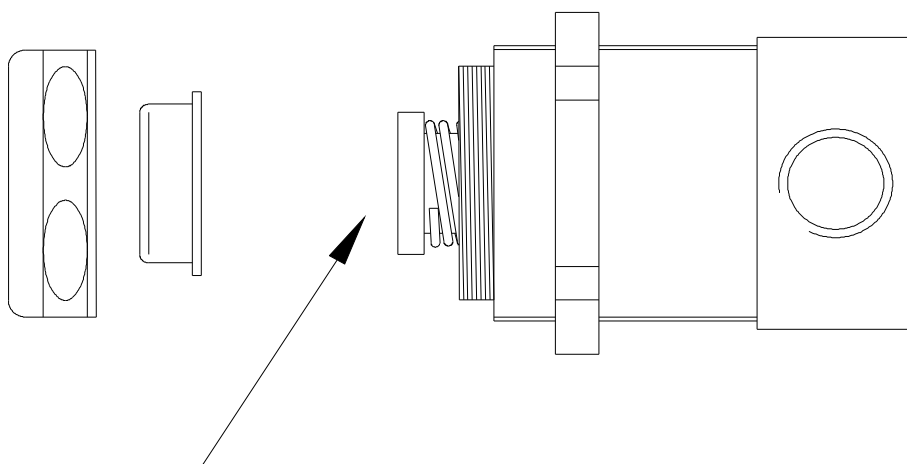

ADJUST THE WATER FLOW BY ROTATING THE SLOT IN THE WHITE HEADED SCREW LOCATED IN THE PUSH BUTTON