



MAESTRO Pressure Coolers

11/17 Powerscroft Road, Sidcup, Kent. DA14 5NH

Telephone: 020 8302 4035 Fax: 020 8302 8933

E-mail: sales@maestrintl.co.uk Website: www.maestrintl.co.uk

Water Coolers* Drinking Fountains* Bottled Water Deliveries * Accessories * Sanitization

Telephone: 020 8302 4035

Fax: 020 8302

Technical Data Sheet

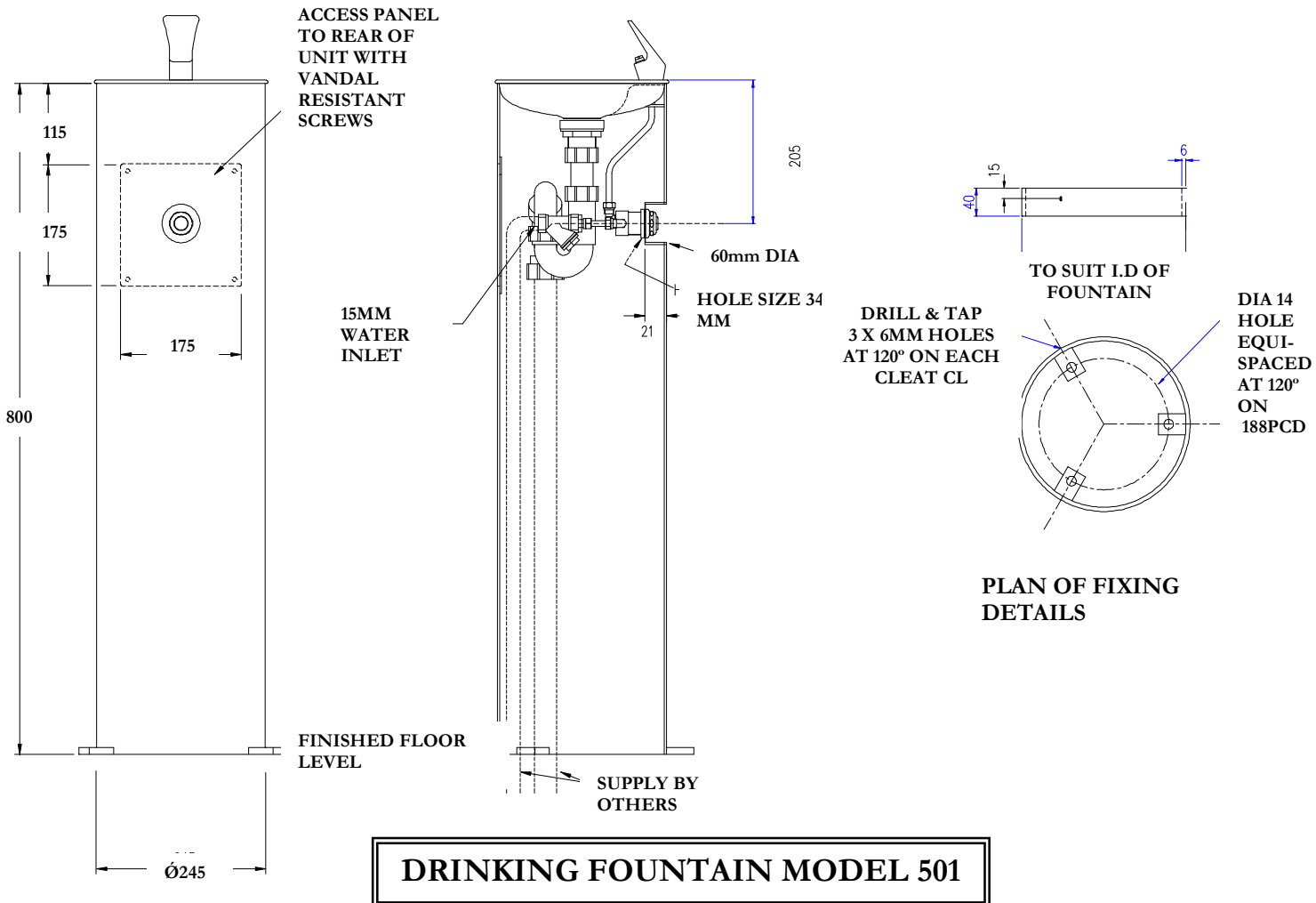

DESCRIPTION:

Specially designed fountain for outdoor use in parks, playground, golf courses and other leisure facilities. The heavy chrome-plated projector is activated by a recessed remote push button regulator located on the front of the fountain.

CONSTRUCTION:

The outer shell of 501 and basin are both made from quality stainless steel, with tamper-proof screws securing the access panel.

SERVICES:

Water inlet: 15mm (1/2" BSP) brass line strainer.
Waste: 32mm multi-fit trap.
Optimum Pressure: 2.5 – 4 bar

PACKAGING:

Dimensions: 1040 x 360 x 360 mm
Weight: 12 kgs



CAUTION

Drinking Fountains On Outside Locations

During winter when temperatures may reach freezing point, it is advisable to drain the water system to prevent damage to the bubbler cartridge.

Ideally, a drain-cock should be fitted downstream of the shut-off cock and before the fountain.

To drain the system:-

1. Close off the shut-off cock and drain off at the drain-cock holding the push button in the open position until all the water has drained away.
2. Close off the drain-cock.

If a drain-cock is not available, the water can be drained in the same manner at the removable plug on the line strainer located inside the fountain.

Please note that frequent use of this item for draining purposes can lead to leakages and it should be considered as a temporary measure until such time that a drain-cock can be fitted.



Water Flow Adjustment

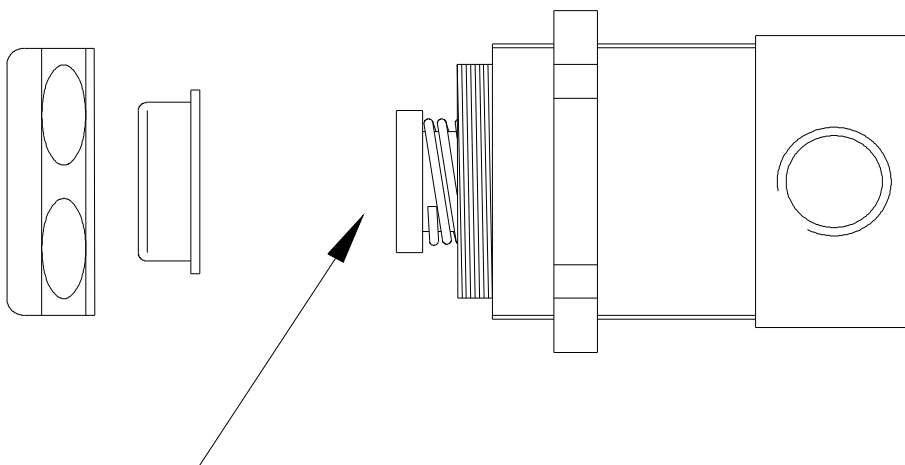

ADJUST THE WATER FLOW BY ROTATING THE SLOT IN THE WHITE HEADED SCREW LOCATED IN THE PUSH BUTTON