



MAESTRO Pressure Coolers

11/17 Powerscroft Road, Sidcup, Kent. DA14 5NH

Telephone: 020 8302 4035 Fax: 020 8302 8933

E-mail: sales@maestrintl.co.uk

Website: www.maestrintl.co.uk

Water Coolers * Drinking Fountains * Bottled Water Deliveries * Accessories * Sanitization

DRINKING FOUNTAIN MODEL F1771

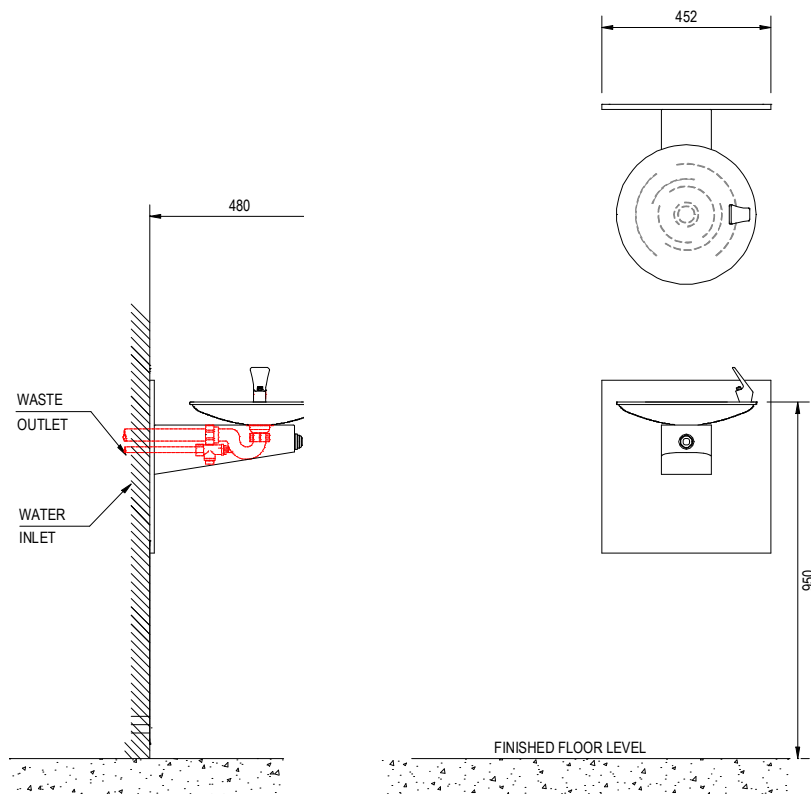

Suggested Specification:

Contractor will supply a circular wall-mounted drinking fountain constructed in heavy gauge stainless steel with splash-back panel. The fountain will have a remote push-button regulator in the front operating a chrome-plated projector. The access plate will be fitted with tamper-proof bolts. **The fountain will be Maestro model F1771**

General Description:

A stainless steel circular drinking fountain with projector activated by a remote push button.

CONSTRUCTION:

Spun stainless steel fountain with contoured basin.

Services:

Water inlet: 15 mm (1/2" BSP) brass line strainer

Waste: 32 mm multi-fit trap.

Packaging:

Dimension:

Weight:



Specifications subject to change without notice



CAUTION

Drinking Fountains On Outside Locations

During winter when temperatures may reach freezing point, it is advisable to drain the water system to prevent damage to the bubbler cartridge.

Ideally, a drain-cock should be fitted downstream of the shut-off cock and before the fountain.

To drain the system:-

1. Close off the shut-off cock and drain off at the drain-cock holding the push button in the open position until all the water has drained away.
2. Close off the drain-cock.

If a drain-cock is not available, the water can be drained in the same manner at the removable plug on the line strainer located inside the fountain.

Please note that frequent use of this item for draining purposes can lead to leakages and it should be considered as a temporary measure until such time that a drain-cock can be fitted.



Water Flow Adjustment

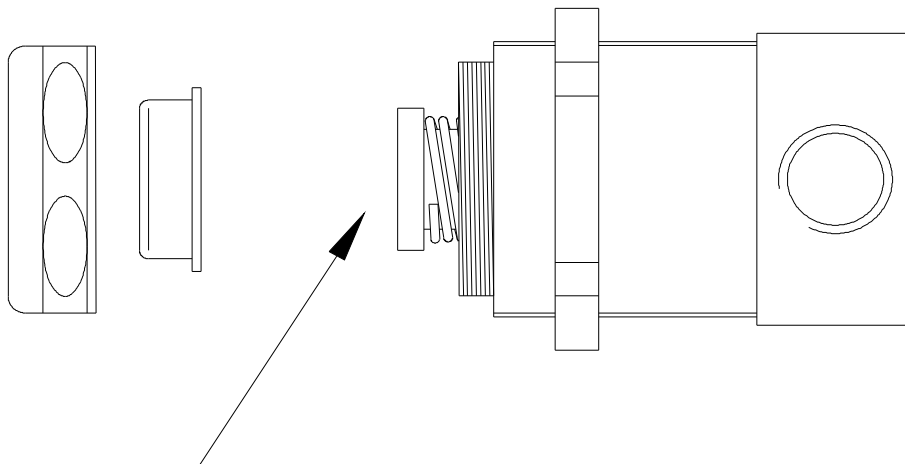

ADJUST THE WATER FLOW BY ROTATING THE SLOT IN THE WHITE HEADED SCREW LOCATED IN THE PUSH BUTTON